

1 Assembling The Tubes

For use with Rocky's 4" Tubing.

Insert the 4" Hub into the end of the Tube.

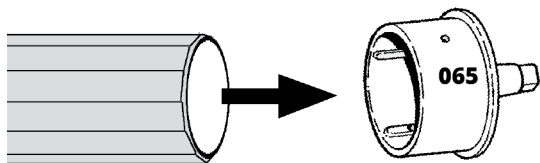

With 2 TEK screws (part 001), attach the Hubs to the Tube using a drill.

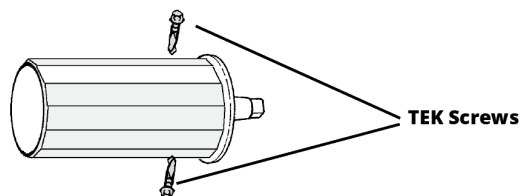

2 Assembling The System

Put the Black Bushing onto the end of the Hub remembering to put some water proof grease inside the Bushing. Grease once a year after that. Push the Tube into the Black Bushing then into the Frame. Put the Washer over the protruding end of the Hub and slide the Handle onto the end of the Hub. Put the Washer on the Bolt and secure the Handle.

VERY IMPORTANT: Do not over tighten the end Bolt as it will make it hard to rotate the Handle.

Repeat this on the other end of the unit and use the Knob in place of the Handle. Your system is now complete.

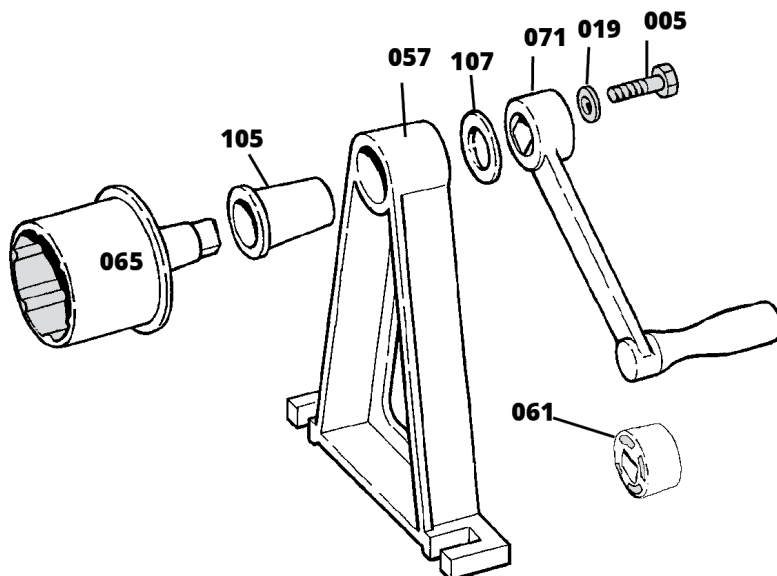

3 Positioning your Reel System

For regular shaped pools, align the outside edge of the Tube parallel with the end of the pool.

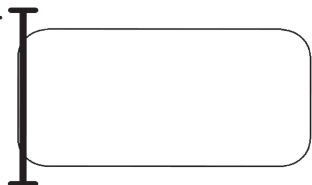

For irregular shaped pools, the outside edge of the Tube should be a minimum of 3' inside from the end of the pool. Place the reel at the widest point for the best result.

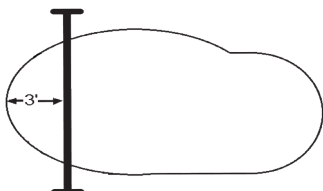

5 Setting The Concrete Anchors

Drive the Concrete Anchor into the hole with a hammer. Leave the Anchor raised 1/16" above pool deck.

To set the Concrete Anchor:

Hit the slug in the center of the Anchor (usually red) with a hammer and center punch, driving the slug down into the Anchor forcing the legs out into concrete. This will stop the Anchor from rotating.

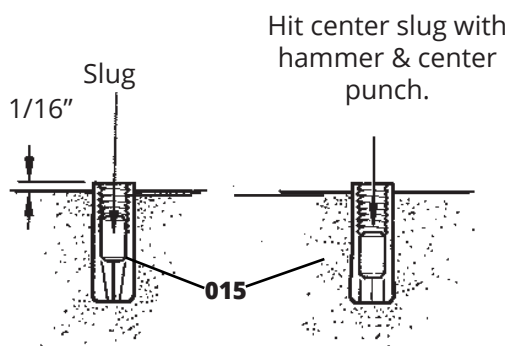

4 Marking The Anchors

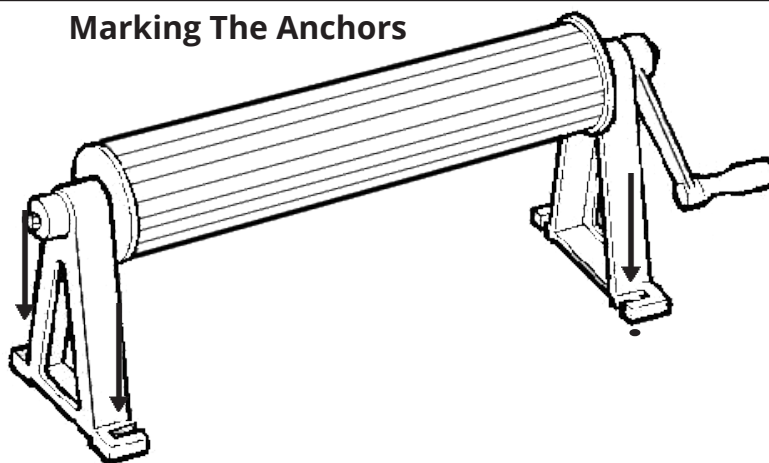

Using the two holes of the Frame as guides, make two marks on the pool deck for each Frame. With a 1/2" concrete drill bit, drill a 1 1/2" deep vertical hole at each mark.

6 Bolting The System To The Pool Deck

Insert the 3/8" Bolts through the 3/8" Washers, through the Frames and into the Concrete Anchors. Tighten the 3/8" Bolts.

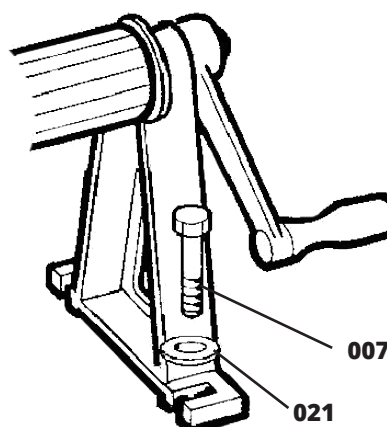

FOR REGULAR SHAPED IN GROUND POOLS

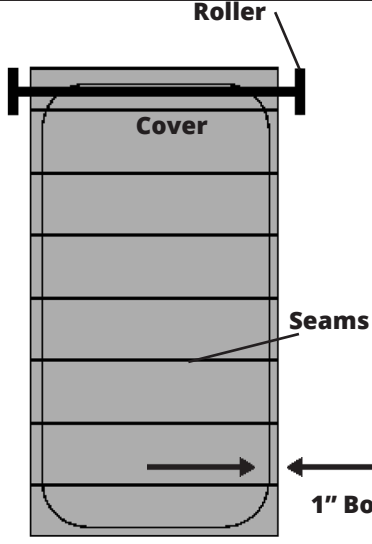

Roller
Cover
Seams
1" Border

Open the cover over the pool and set it into position. Ensure that the end of the cover (where it attaches to the roller) is square to the roller.
When cutting the cover, allow a 1" wide border around the pool edge to compensate for shrinkage.
If the cover has seams, then the seams should be parallel to the roller. (This may not be possible with some types of covers.)

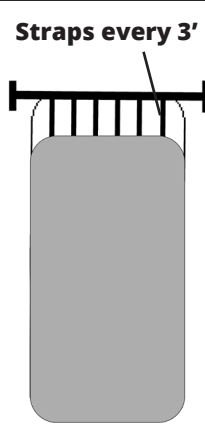

Straps every 3'

Attach the cut cover to the roller with the blue straps (see Grommet detail). Ensure the length of the strap allows the cover to lay flat on pool, to prevent wind from getting under the cover.
To measure your straps go from the top of the assembled reel system down to the water in your pool and then add two inches extra to compensate for evaporation.

FOR IRREGULAR, KIDNEY, OR ROUND SHAPED IN GROUND POOLS

Open the cover over the pool and set it into position. Ensure that the seams on the cover are parallel to the roller. (This may not be possible with some types of covers).

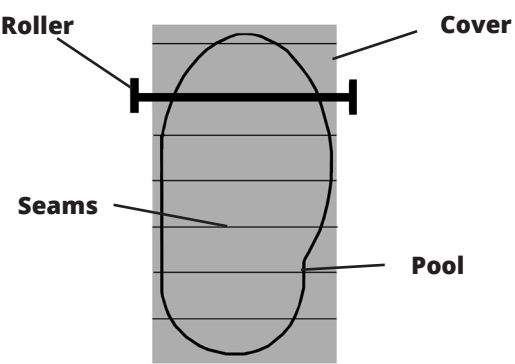

Roller
Cover
Seams
Pool
1" Border

When cutting the cover, allow a 1" wide border around the pool edge to compensate for shrinkage.

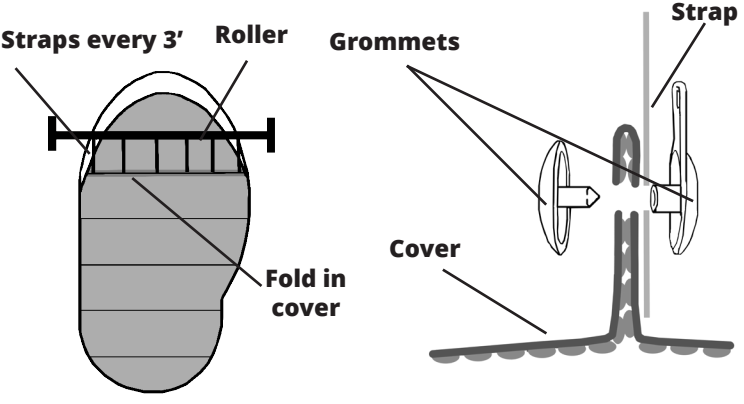

Straps every 3'
Roller
Grommets
Strap
Cover
Fold in cover

For odd shaped pools, pinch the cover and attach the strap as shown. Attach the cut cover to the roller with the blue straps (see grommet detail) by folding the cover in a straight line as shown in the diagrams. Ensure that the fold in the cover is straight.

GROMMET DETAIL

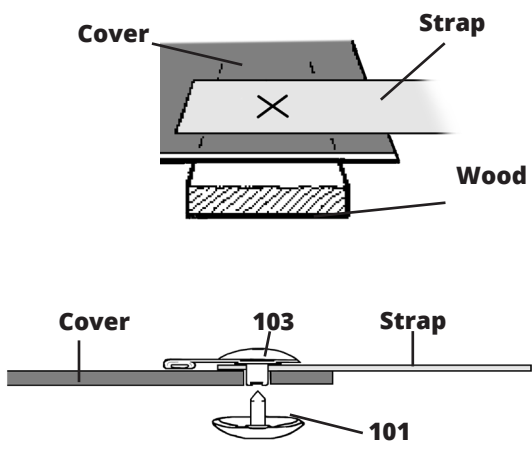

Cover
Strap
Wood
Cover
Strap
103
101

Position the blue strap on the cover. Cross cut through the strapping and the cover. Ensure that the hole in the strapping is at least 1" from the end of the strap and that the hole in the cover is at least 2" from the end of the cover. If possible fold the edge of the cover over so that you put the Grommet through two layers of cover.
This will ensure that the Grommet fits securely onto both the cover and the strap, and will help to prevent tearing.

Insert the Female Grommet through your cut in the strapping and the cover. Ensure that the material is completely pushed down on the shaft. Insert the Male Grommet into Female Grommet. Once in place, hit with a hammer until secure. (**Caution - excessive force will break grommet.**)

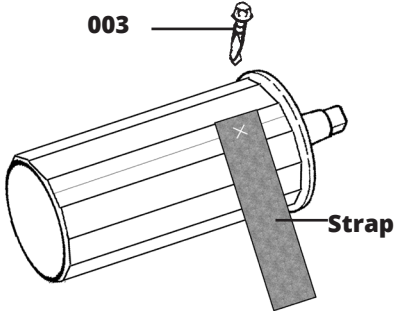

003
Strap

Using 5/8" Tek Screws, secure the strap to the Tube. Make sure you put the screw about an inch into the strap to prevent tearing.

ITEM #	QTY.	DESCRIPTION	RE-ORDER #
001	4	7/8" TEK Screw	501
003	10	5/8" TEK Screw	501
005	2	5/16"x1" Bolt	505
007	4	3/8"x1" Bolt	507
015	4	Concrete Anchor	515
019	2	5/16" Washer	505
021	4	3/8" Washer	21
057	2	#4 A-Frame	531
061	1	Knob	533
065	2	4" Hub	539
071	1	Small Handle	545
101	10	Male Grommet	549
103	10	Female Grommet	549
105	2	Plastic Bushing	555
107	2	Plastic Washer	555
201	1	22' Strapping	587

Tools Required

Drill
1/2" Concrete (masonry) Drill Bit
Hammer & Center Punch
5/16" Hex Head Socket Bit
1/2" Wrench
5/8" Wrench

Rocky's Reel Systems Inc.
Tel: 1-800-663-8705 E-Mail: info@rockys.ca
For further instructions and how to videos visit www.rockys.ca