

#3 Portable Assembly Instructions



1 Assembling the Tubes

Please see the instructions supplied in the Tube box before going any further.

Very important:

You must use the Bolts supplied or the Tube may sag. When you have assembled the Tube according to the instructions put the 4" Hubs in each end of the Tube.

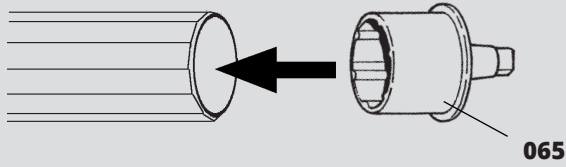

Using 4 of the TEK screws (2 for each hub) attach the 4" Hubs to the Tubes.

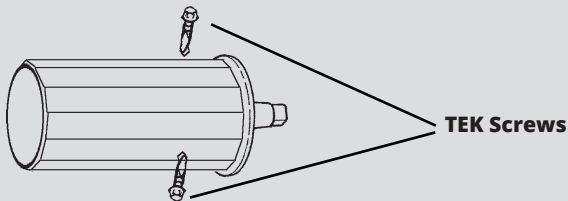

2 Assembling The End Units

Put a 3/8" Washer onto the Wheel Stem and then put the 021 Stem through one of the outer holes of the Frame followed by another Washer and then an Acorn Nut. Tighten the Acorn Nut with a 5/8" wrench.

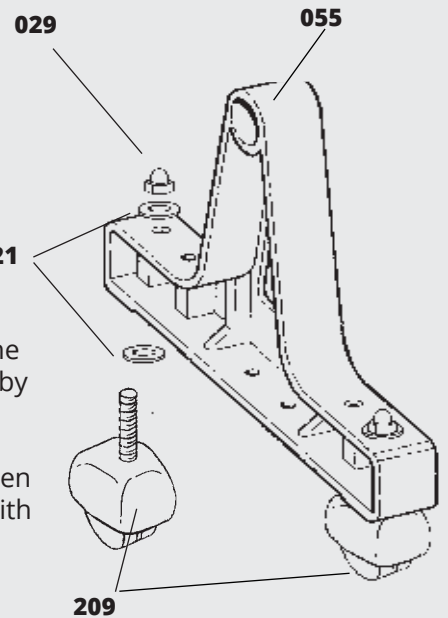

Repeat these steps for all four Wheels.

3 Assembling The Reel System

Put the Black Bushing onto the end of the Hub remembering to put some waterproof grease inside the Bushing. Grease once a year after that.

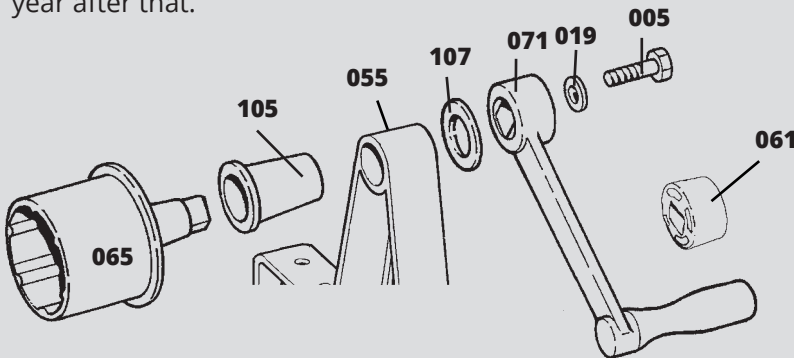

Push the Hub with the Black Bushing into the Frame. Put the Black Washer over the end of the protruding end of the Hub and slide the Handle onto the end of the Hub. Put the Washer on the Bolt and secure the Handle. **VERY IMPORTANT:** Do not overtighten this Bolt as it will make it hard to rotate the Handle. Repeat this on the other end of the unit and use the Knob in place of the Handle.

4 Positioning your Reel System

For regular shaped pools, align the outside edge of the Tube parallel with the end of the pool.

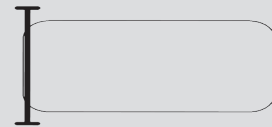

For irregular shaped pools, the outside edge of the Tube should be a minimum of 3' inside from the end of the pool. Place the reel at the widest point for a better result.

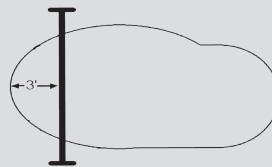

5

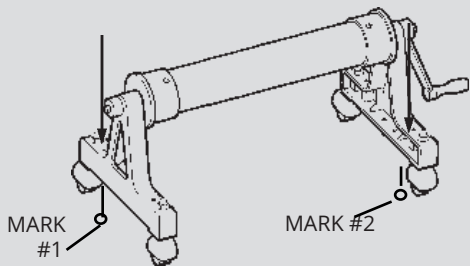

Using one of the two holes in the Frame as a guide, make mark #1 on deck. With a 1/2" concrete drill bit, drill a 1 1/2" deep hole at mark #1. Complete steps 6 and 7 before continuing to the other side of the unit. On the other side of the roller unit, make mark #2 by using one of the two holes in the Frame as a guide. With a 1/2" concrete drill bit, drill a 1 1/2" deep hole at mark #2. **NOTE:** Set one bolt at front of Frame on one end and one at the rear of the Frame on the other end.

6

Drive the Concrete Anchor into the hole with a hammer. Leave the Anchor raised 1/16" above deck.

To set the Concrete Anchor:

Hit the slug in the center of the Anchor (usually Red) with a hammer and center punch, driving the slug down into the Anchor forcing the legs out into the concrete.

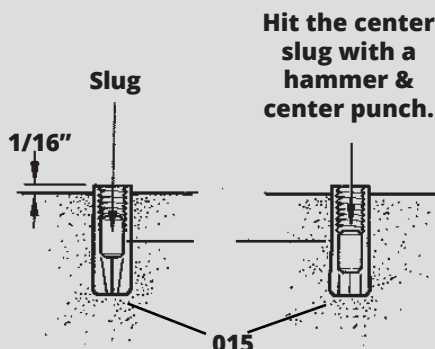

7

Insert the Anchor Bolt through the Spring, through the Black Spring Guard and through the hole of the Frame.

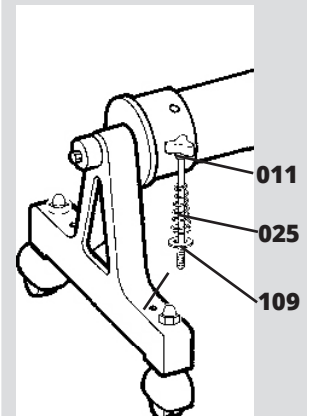

FOR REGULAR SHAPED INGROUND POOLS

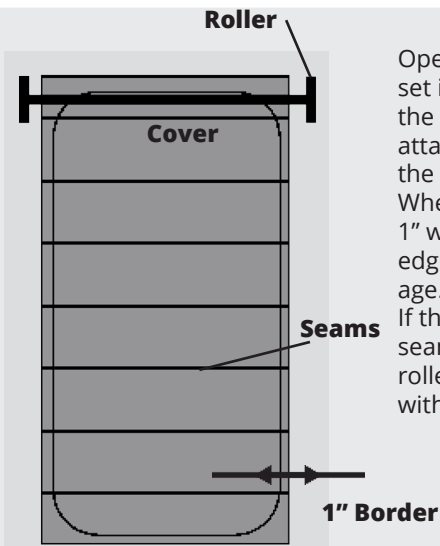

Open the cover over the pool and set it into position. Ensure that the end of the cover (where it attaches to the roller) is square to the roller.
When cutting the cover, allow a 1" wide border around the pool edge to compensate for shrinkage.
If the cover has seams, then the seams should be parallel to the roller. (This may not be possible with some types of covers.)

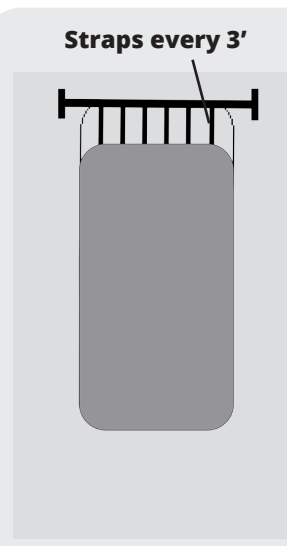

Attach the cut cover to the roller with the blue straps (See Grommet detail). Ensure the length of the strap allows the cover to lay flat on pool, to prevent wind from getting under the cover.
To measure your straps go from the top of the assembled reel system down to the water in your pool and then add two inches extra to compensate for evaporation.

FOR IRREGULAR, KIDNEY, OR ROUND SHAPED INGROUND POOLS

Open the cover over the pool and set it into position. Ensure that the seams on the cover are parallel to the roller. (This may not be possible with some types of covers).

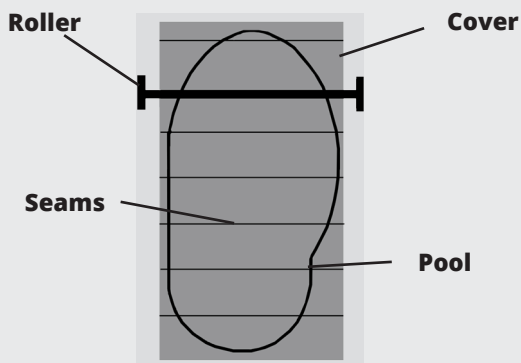

When cutting the cover, allow a 1" wide border around the pool edge to compensate for shrinkage.

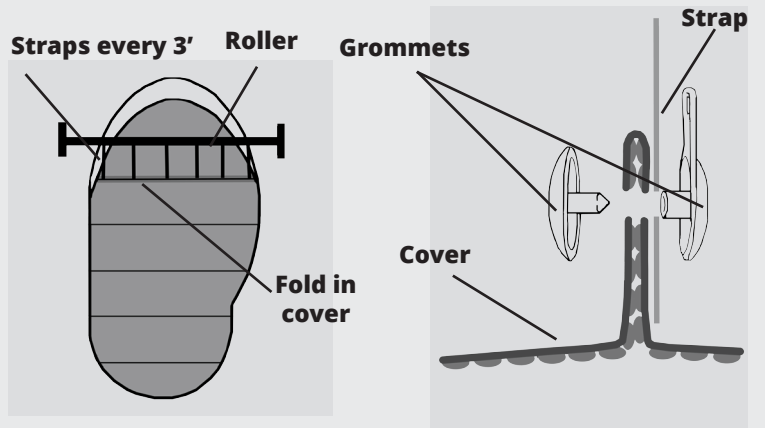

For odd shaped pools, pinch the cover and attach the strap as shown. Attach the cut cover to the roller with the blue straps (see Grommet detail) by folding the cover in a straight line as shown in the diagrams. Ensure that the fold in the cover is straight.

GROMMET DETAIL

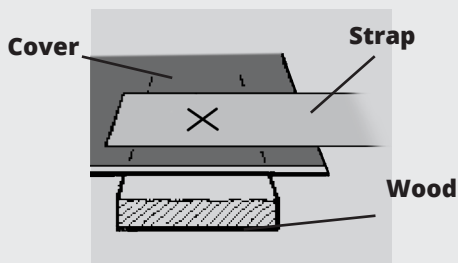

Position the blue strap on the cover. Cross cut through the strapping and the cover. Ensure that the hole in the strapping is at least 1" from the end of the strap and that the hole in the cover is at least 2" from the end of the cover. If possible fold the edge of the cover over so that you put the Grommet through two layers of cover.

This will ensure that the Grommet fits securely onto both the cover and the strap, and will help to prevent tearing.

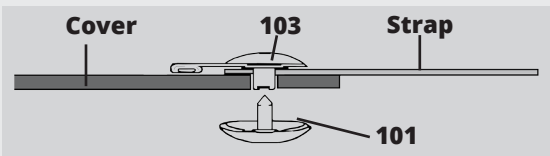

Insert the Female Grommet through your cut in the strapping and the cover. Ensure that the material is completely pushed down on the shaft. Insert the Male Grommet into Female Grommet. Once in place, hit with a hammer until secure. (**Caution - excessive force will break grommet.**)

| ITEM # | QTY. | DESCRIPTION | RE-ORDER # |
|--------|------|---------------------|------------|
| 1 | 12 | TEK Screw | 501 |
| 5 | 2 | 5/16"x1" Bolt | 505 |
| 11 | 2 | 3/8"x6" Anchor Bolt | 511 |
| 15 | 2 | Concrete Anchor | 515 |
| 19 | 2 | 5/16" Washer | 505 |
| 21 | 8 | 3/8" Washer | 583 |
| 25 | 2 | Spring | 517 |
| 29 | 4 | Acorn Nut | 523 |
| 55 | 2 | #3 A-Frame | 530 |
| 61 | 1 | Knob | 533 |
| 65 | 2 | 4" Hub | 539 |
| 71 | 1 | Small Handle | 545 |
| 101 | 10 | Male Grommet | 549 |
| 103 | 10 | Female Grommet | 549 |
| 105 | 2 | Plastic Bushing | 555 |
| 107 | 2 | Plastic Washer | 555 |
| 109 | 2 | Spring Guard | 517 |
| 201 | 1 | 22' Strapping | 587 |
| 209 | 4 | 2" Plastic Wheels | 583 |

Tools Required:

| |
|-----------------------------------|
| Reversible Electric Drill |
| 1/2" Concrete (masonry) Drill Bit |
| Hammer & Center Punch or Nail |
| 5/16" Hex Head Socket Bit |
| 1/2" Wrench |
| 5/8" Wrench |

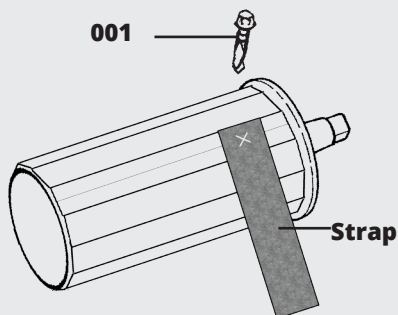

Using Tek Screws, secure the strap to the Tube. Make sure you put the screw about an inch into the strap to prevent tearing.

Rocky's Reel Systems Inc.

Tel: 1-800-663-8705 E-Mail: info@rockys.ca

For further instructions and how to videos visit rockys.ca